



MUSICAL EQUIPMENT

2024 CATALOG





MUSICAL EQUIPMENT

STANDS

MS-WB812

SPEAKER WALL BRACKET

- Dimension: 11 cm
- Weight Capacity: 25 Kg
- Material: Sheet Iron
- Tilt Swivel Feature: Tilt
- Tilt: 20°
- Most 8", 10" and 12" DJ Cabinets

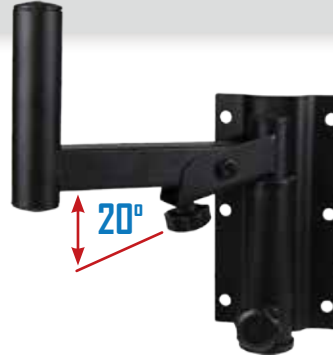

MS-WB1215

SPEAKER WALL BRACKET

- Dimension: 11 cm
- Weight Capacity: 25 Kg
- Material: Sheet Iron
- Tilt Swivel Feature: Tilt
- Tilt: 20°
- Most 12" and 15" DJ Cabinets

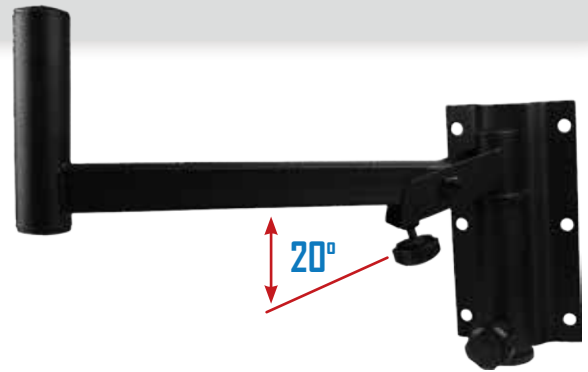

MS-PE12

TUBE EXTENSION

- Outer Tube (Diameter x Height): 41.7 mm x 820 mm
- Inner Tube (Diameter x Height): 35mm x 820 mm



MS-SE49

SUBWOOFER TO SATELLITE SPEAKER POLE

- Steel tubing with Plastic housing
- Match both 35mm and 38mm speaker mount diameters
- Fit subwoofers with M20 threaded sockets
- Supplied with steel pin security system
- Compact Overall (HxWxL) : 805x70x60mm (31.7"x2.8"x2.4")
- Height Adjustable (Min - Max): 720 - 1225mm (28.3" - 48.2")
- Max Weight Capacity: 60 lbs (27kg)
- Color / Finish: Black / Powder-coated





MUSICAL EQUIPMENT

STANDS

MSKB-91

MIXER AND KEYBOARD STAND

- Adjustable Height: 20.9" - 37.8" (530-960 mm)
- Bottom Pipe: 18.1" (360 mm)
- Top Pipe: 14.2" (360 mm)
- Loading Capacity: 110 lbs (50 kg)
- Color: Black



MAR-300

PROFESSIONAL MIXER STAND

- For 18.9 x 16.9 inch (480 x 430 mm) DJ Mixer
- TILT: 45° DOWN
- Maximum DJ Mixer Weight: 60 kg (132 lbs)
- Product Parameter:
H: 34.6 inch (880 mm)
W: 17.6 lbs (8 kg)
- Slanting Pipe: 21.7~35.4 inch (550-900 mm)



MAR-LT200

LAPTOP BRACKET

- Black Spray-Painted Iron
- Height & Width Adjustable
- Fix with Screwed Clamp



Clamps for DJ Flight Case

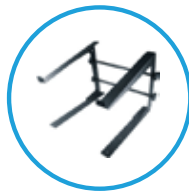

Base for DJ Table



MAR-LTF300

LAPTOP BRACKET

- Black Spray-painted Iron
- Portable: The unit is very easy to assemble or disassemble for portability
- Broad Compatibility
- Ultra-Stable & Heavy Duty



FOR 10"-17" LAPTOP

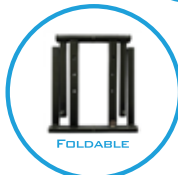

FOLDABLE



CARRY BAG INCLUDED





MUSICAL EQUIPMENT

STANDS

MSKB-100

KEYBOARD STAND

- Adjustable Height: 26.8" ~ 39.4"
- Bottom Pipe: 25.2", Top Pipe: 16.1"
- Weight: 4.5 kg



MSKB-101

KEYBOARD STAND

- Adjustable Height: 23.8" ~ 39" (605~990 mm)
- Bottom Pipe: 17.9" (455 mm)
- Top Pipe: 14" (355 mm)
- Loading Capacity: 88.2 lbs (40 kg)
- Weight: 7.1Lbs (3.2 kg)



MSKB-200

DOUBLE KEYBOARD STAND

- Adjustable Height: 39.4" ~ 49.6"
- Bottom Pipe: 25.2", Top Pipe: 16.1"
- Weight: 5.8 kg





MUSICAL EQUIPMENT

STANDS

MS-9

PROFESSIONAL P. A. SPEAKER STAND

- Height Adjustment Grip
- Height: 2 5.6" - 48.0" (650-1220 mm)
- Weight: 4.9 Lbs (2.2 kg)
- Supports up to: 110 Lbs (50 kg)
- Tube Thickness: 0.8 mm



MS-11

PROFESSIONAL P. A. SPEAKER STAND

- Stand with P.A. Speaker Holder
- Height Adjustment Grip
- Height: 39.4" - 74.0" (1000 - 1880 mm)
- Weight: 8.4 Lbs (3.8 kg)
- Supports up to: 165 lbs (75 kg)
- Tube Thickness: 0.8 mm



MS-16LED

SPEAKER STAND WITH LED

- Height range: 39"~71" (99~180cm)
- Folded length: 35.4" (90cm)
- Load capacity: 55lbs (25kg)
- Weight: 6.2lbs (2.8kg)
- Uses heavy-duty steel tubing
- Easy and fast height adjustments
- Cast-alloy tripod leg base to ensure maximum stability
- AC/DC: 100~240VAC 50/60Hz 12V 2A

Features:

- Perfectly fits socket below enclosure
- Adjustable heights
- All parts are replaceable
- Remote control with programs and options
- RGB Colors spectrum available



DS-201

PLASTIC BASE

- Plastic Base for P. A. Speaker Stands



DS-203

ALUMINUM BASE

- Aluminum Base for P. A. Speaker Stands



DS-205

IRON BASE

- Iron Base for P. A. Speaker Stands



DS-303

BASE

- Base for D-11





MUSICAL EQUIPMENT

STANDS

F-8

BOOM FLOOR STAND

- Boom Floor Stand with Die Cast Base
- Black Finished



MS-2

MICROPHONE STAND

- Stand with Microphone Holder
- Height Adjustment Grip
- Product Parameter:
Height: 37.8" - 55.1"
(661-1680 mm)
Weight: 9.9 lbs (4.5 kg)
- Stage Microphone



MS-5

MICROPHONE STAND

- Microphone Stand with Boom Mic Holder and Height Adjustment
- Black Finished



MS-5CHR

MICROPHONE STAND

- Adjusts Up to 6'
- Height: 31.5" ~ 55.1"
- Weight: 3.1 lbs
- Slating Pipe: 29.5"
- Chrome Finish



MS-6

MICROPHONE STAND

- Adjusts to Different Heights
- Height: 38.6" ~ 66.1"
- Weight: 3.7 lbs
- Cross Pipe: 29.5"



MS-13

MICROPHONE STAND

- Microphone Stand with Adjustable Angle and Height Adjustment
- Black Finished





MUSICAL EQUIPMENT

STANDS

MSQ-57

MICROPHONE STAND

- Adjusts up to 6'
- Parameter: H 41.3 - 66.1" W: 7.7 Lbs
- Slanting Pipe: 21.7 - 35.4"
- Includes 1 Microphone Clamp
- Microphone Stand with Boom Mic Holder and Quick Grip Height Adjustment



MSMS-51

MUSIC SHEET STAND FOLDABLE

- Height Adjustable, Foldable Legs, Lightweight, Metal Construction
- Two Section Design with Adjustable Angle Desk
- Stand Includes Wire Music Clips and Rubber Feet
- Stand Folds to 21-1/2 inches, Folding Tripod Design
- Height Adjustment to 36 inches



MSMS-52

FOLDABLE SHEET MUSIC STAND WITH CLIPS

- Height Adjustable, Foldable Legs, Lightweight, Metal Construction
- Two Section Design with Adjustable Angle Desk
- Stand Includes Wire Music Clips and Rubber Feet
- Stand Folds to 21-1/2 inches, Folding Tripod Design
- Height Adjustment



MSG-23

GUITAR A FRAME STAND

- Safe and Stable: this guitar A stand provides better stability
- Durable and Convenient: made of quality iron for excellent strength
- Upgraded Folding Guitar Stand: the upgraded stand can tilt 95° and fold
- Wide Application: universal guitar stand acoustic electric guitar, bass guitar, banjo, ukulele, mandolin, violin, kids guitar, etc.



MS-ITBLT

MULTIMEDIA TABLET HOLDER FOR STANDS

- Fully Adjustable Multimedia Tablet Holder
- Pivot, Tilt, Rotate, Raise and Lower
- Pole Height: 18.5~32cm
- Accommodates Tablets from: 10.7cm to 20cm



Two Mounting OPTIONS

MS-IMBL

MICROPHONE STAND TABLET & PHONE HOLDER

- Suitable for 4.13 - 9.05 inch Tablets and Multimedia devices
- 90° Rotation
- Infinite angle adjustment
- Extends 3.7" Diameter 5.9"



Extended OPTION



MUSICAL EQUIPMENT

STANDS

MS-LS101

DJ STAND

- Universal Laptop Notebook Placement
- Rugged and Durable Metal Construction
- Convenient Sound Equipment Placement
- Quick and Easy Setup
- Lightweight, Portable and Reliable
- Tripod Floor Standing Design
- Quick and Convenient Height Adjustments
- Minimum Height: 26"
- Maximum Height: 44.1"
- Weight: 6.8 lbs
- Perfect for On-Stage or In-Studio Use
- Folds Completely for Travel and Storage
- Shelf/Plate Size: 16" x 20"
- Glossy Black Finish



Laptop
No Included



Adjustable
Stabilization Adjustable
Angle/Height

F-915

BOOM FLOOR STAND PIG
IRON DIE CASTING

- Height: 35-62 cm
- ARM Length: 40 cm
- Weight: 1.62 Kg
- PIG Iron Die casting: 14mm



F-917

BOOM FLOOR STAND

- Height: 35-55 cm
- ARM Length: 40 cm
- Weight: 2.542 Kg
- Spray Plastic: Ø180mm



F-3

DESK STAND

- Microphone Desk Stand



F-4

DESK STAND

- Desk Stand with Die Cast Base

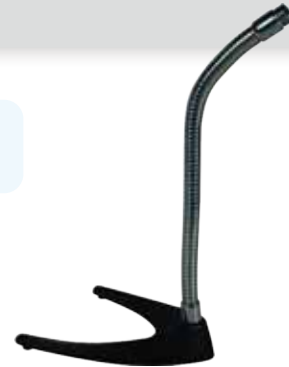

F-6

DESK STAND

- Microphone Desk Stand



F-7M

GOOSE NECK DESK STAND

- 8" / 21 cm





MUSICAL EQUIPMENT

HOLDERS

A-IS BLK

EZ SLIP-IN CLAMP

- Single Microphone Holder
- Malleable to Fit Most Standard and Oversized Microphones
- Black Color



A-IS WHT

EZ SLIP-IN CLAMP

- Single Microphone Holder
- Malleable to Fit Most Standard and Oversized Microphones
- White Color



A-2

SINGLE MICROPHONE HOLDER

- Spring Type Holder
- Black Color



A-3

SINGLE MICROPHONE HOLDER

- Slide Type Holder
- Black Color



A-52

2 MIC HOLDER

- Break Resistant
- Fits Standard Microphone Stands
- For 1" and Large Handles
- Black Color



A-54

4 MIC HOLDER

- Break Resistant
- Fits Standard Microphone Stands
- For 1" and Large Handles
- Black Color





MUSICAL EQUIPMENT

HOLDERS / ACCESSORIES

A-5

MICROPHONE CLIP HOLDER MIC STAND ACCESSORY

- Small Size



A-6

MICROPHONE CLIP HOLDER MIC STAND ACCESSORY

- Large Size



A-10

SLIDE TYPE HOLDER

- Copper Screw



D-8 (13")

D-8-19 (19")

FLEXIBLE GOOSE NECK

- Metal

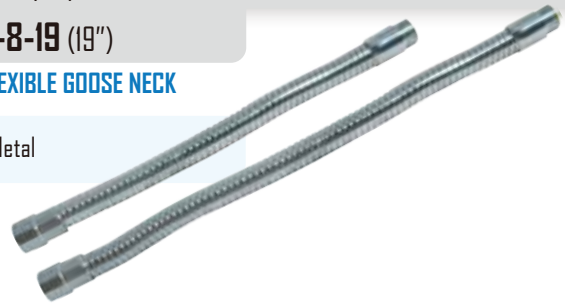

D-8BLK

13" FLEXIBLE GOOSE-NECK FOR MICROPHONES

- Heavy-Duty Flexible
- Structure material: iron



D-14

MALE GOOSE NECK BASE

- Metal



D-15

FEMALE GOOSE NECK BASE

- Metal



F-SCREW

ON-STAGE STAND MIC SCREW ADAPTER

- 5/8 Male to 3/8 Female Screw Adapter for Use with Mic Stands that have European 3/8" Threads
- Sold Individually





MUSICAL EQUIPMENT

MACHINE HEADS

ADD-017A (W)

GUITAR REPLACEMENT
TUNING KEYS

- Nickel-Plated Tuning Keys (Short)
- Steel Pegs



ADD-018C (W)

GUITAR REPLACEMENT
TUNING KEYS

- Nickel-Plated Tuning Keys (Long)
- Plastic Pegs



ADD-019C (W)

GUITAR REPLACEMENT
TUNING KEYS

- Gold-Plated Tuning Keys (Long)
- Plastic Pegs

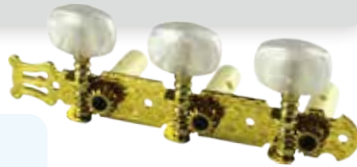

ADD-017AP

GUITAR ACCESSORIES

- Machine Head

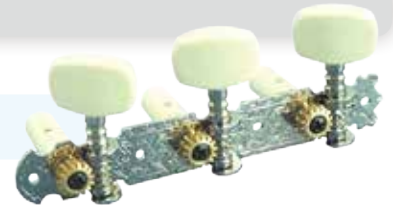

ADD-018CP

GUITAR ACCESSORIES

- Nickel 3 Machine Head (Long)

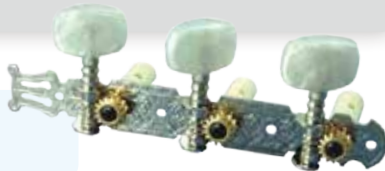

ADD-019CP

GUITAR ACCESSORIES

- Gold 3 Machine Head (Long)

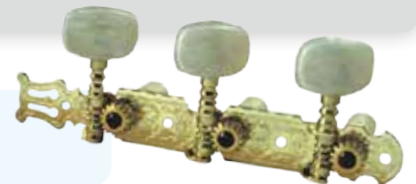

AS-016P

LOCKED MACHINE HEAD

- Single Chrome-Plated Locked Machine Head



AOS-020BIP

MACHINE HEAD

- Gold Plated 3 Machine Head (Short)





MUSICAL EQUIPMENT

GUITAR CAPOS / GUITAR STRINGS

A007A/BK

GUITAR CAPO

- Acoustic



A007B

CLASSIC GUITAR CAPO

- Metal Finish

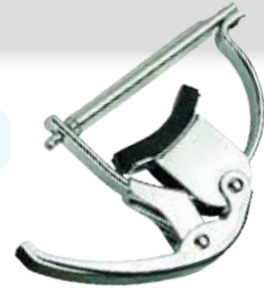

A007C/BK

GUITAR CAPO

- Classical



A007D/SL-A

ACOUSTIC GUITAR CAPO

- With Polished Finish



A007D/BK-C

GUITAR CAPO

- Classical Guitars



A007D/SL-C

CLASSIC GUITAR CAPO

- With Polished Finish



AC106-H COMPLETE KIT

- AC106-H-1
- AC106-H-2
- AC106-H-3
- AC106-H-4
- AC106-H-5
- AC106-H-6

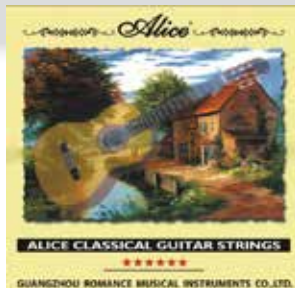

CLASSICAL GUITAR STRING

- Plastic Bag

KIT		Inch	mm
AC106-H-1	Clear Nylon	.0285	0.72
AC106-H-2	Clear Nylon	.0325	0.83
AC106-H-3	Clear Nylon	.041	1.04
AC106-H-4	Silver-Plated Copper Wound	.030	0.76
AC106-H-5	Silver-Plated Copper Wound	.36	0.91
AC106-H-6	Silver-Plated Copper Wound	.044	1.12

AC136BK-N

CLASSIC GUITAR STRING

- Black Nylon
- Nylon Core
- Coated Copper Wound
- Proprietary Anti-Rust Coat



AC136BK-N KIT	Inch	mm
Black Nylon	.028	0.71
Black Nylon	.032	0.81
Coated Copper Alloy Wound	.025	0.63
Coated Copper Alloy Wound	.029	0.74
Coated Copper Alloy Wound	.035	0.89
Coated Copper Alloy Wound	.043	1.09



MUSICAL EQUIPMENT

GUITAR STRINGS

AC107BK-H COMPLETE KIT

- AC107BK-H-1
- AC107BK-H-2
- AC107BK-H-3
- AC107BK-H-4
- AC107BK-H-5
- AC107BK-H-6



GUITAR STRING

- Plastic Bag

KIT		Inch	mm
AC107BK-H-1	Black Nylon	.0285	0.72
AC107BK-H-2	Black Nylon	.0325	0.83
AC107BK-H-3	Black Nylon	.041	1.04
AC107BK-H-4	Gold-Plated Copper Alloy Wound	.030	0.76
AC107BK-H-5	Gold-Plated Copper Alloy Wound	.36	0.91
AC107BK-H-6	Gold-Plated Copper Alloy Wound	.044	1.12

AC107-N

CLASSICAL GUITAR STRING

- Clear Nylon
- Silver-Plated Copper Alloy Winding

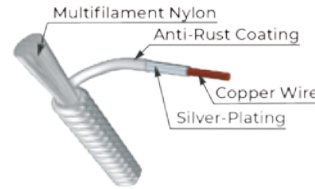

	E-1st	B-2nd	G-3rd	D-4th	A-5th	E-6th	
N (Normal Tension)	.028	.032	.040	.029	0.35	.043	inch
	0.71	0.81	1.02	0.74	0.89	1.09	mm
H (Hard Tension)	.0285	.0325	.041	.030	0.36	.044	inch
	0.72	0.83	1.04	0.76	0.91	1.12	mm

A2012

ACOUSTIC FOLK GUITAR STRINGS

- Acoustic Guitar Stainless Steel
- Steel Core
- Coated Copper Alloy

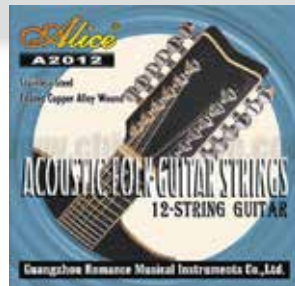

A2012 KIT	Inch	mm
Stainless Steel	.010	0.25
Stainless Steel	.010	0.25
Stainless Steel	.014	0.36
Stainless Steel	.014	0.36
Coated Copper Alloy Wound	.022	0.56
Stainless Steel	.008	0.20
Coated Copper Alloy Wound	.030	0.76
Stainless Steel	.012	0.30
Coated Copper Alloy Wound	.040	1.02
Stainless Steel	.018	0.46
Coated Copper Alloy Wound	.050	1.27
Coated Copper Alloy Wound	.026	0.66

A307-SL COMPLETE KIT

- A307-SL-1
- A307-SL-2
- A307-SL-4
- A307-SL-5
- A307-SL-6



ACOUSTIC GUITAR STRINGS

- Acoustic Guitar, Stainless Steel, Silver Plated, Copper Alloy Winding

A306-SL KIT		Inch	mm
E-1st	Stainless Steel	.011	0.25
B-2nd	Stainless Steel	.015	0.38
G-3rd	Silver-Plated Copper Alloy Wound	.024	0.61
D-4th	Silver-Plated Copper Alloy Wound	.032	0.81
A-5th	Silver-Plated Copper Alloy Wound	.042	1.07
E-6th	Silver-Plated Copper Alloy Wound	.052	1.32



MUSICAL EQUIPMENT

GUITAR STRINGS

A406-SL

ACOUSTIC GUITAR STRINGS

- Acoustic Guitar, Stainless Steel, Bronze Wound, Light Strings

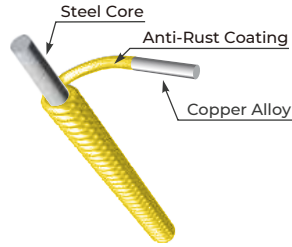

A406-SL (Super Light) KIT

	Inch	mm
Stainless Steel	.011	0.28
Stainless Steel	.015	0.38
Coated Copper Alloy Wound	.024	0.61
Coated Copper Alloy Wound	.032	0.81
Coated Copper Alloy Wound	.042	1.07
Coated Copper Alloy Wound	.052	1.32

A408-SL

ACOUSTIC GUITAR STRINGS

- Acoustic Guitar, Stainless Steel, Silver Plated, Copper Wound, Extra-Light Strings

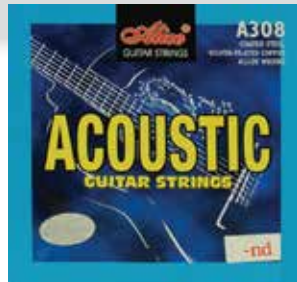

A406-L

ACOUSTIC GUITAR STRINGS

- Acoustic Guitar, Stainless Steel, Bronze Wound, Light Strings



A308-SL Super Light

Note	Inch	mm
E	.011	0.28
B	.015	0.38
G	.024	0.61
D	.032	0.81
A	.042	1.07
E	.052	1.32

A406-L KIT

	Inch	mm
Stainless Steel	.012	0.30
Stainless Steel	.016	0.41
Coated Copper Alloy Wound	.024	0.61
Coated Copper Alloy Wound	.032	0.81
Coated Copper Alloy Wound	.042	1.07
Coated Copper Alloy Wound	.053	1.35

APL009

ELECTRIC OR ACOUSTIC GUITAR PLAIN STRING

- Plain Steel



APL011

ELECTRIC OR ACOUSTIC GUITAR PLAIN STRING

- Plain Steel



APL 009

Electric	Inch	mm
SL-1	.009	0.23

APL 011

Electric	Inch	mm
SL-2	.011	0.28



MUSICAL EQUIPMENT

GUITAR STRINGS

A407C-SL

ACOUSTIC GUITAR STRINGS

- Colorful strings for Acoustic Guitar
- Stainless Steel
- Steel Core
- Colorful Coated Copper Alloy Winding



Note	Inch	mm
E-1st	.011	0.28
B-2nd	.015	0.38
G-3rd	.024	0.61
D-4th	.032	0.81
A-5th	.042	1.07
E-6th	.052	1.32



A 506-SL

- A 506-SL-1
- A 506-SL-2
- A 506-SL-3
- A 506-SL-4
- A 506-SL-5
- A 506-SL-6



ELECTRIC GUITAR STRING

- Electric Guitar, Stainless Steel, Nickel Round Wound, Extra-Light Strings

A506-SL KIT		Inch	mm
A 506-SL-1	Plated Steel	.009	0.23
A 506-SL-2	Plated Steel	.011	0.28
A 506-SL-3	Plated Steel	.016	0.41
A 506-SL-4	Nickel Alloy Wound	.024	0.61
A 506-SL-5	Nickel Alloy Wound	.032	0.81
A 506-SL-6	Nickel Alloy Wound	.042	1.07

A 507-SL

- A 507-SL-1
- A 507-SL-2
- A 507-SL-3
- A 507-SL-4
- A 507-SL-5
- A 507-SL-6



ELECTRIC GUITAR STRING

- Electric Guitar, Plated Steel, Nickel Alloy Wound, Nickel-Plated Ball-End, Plastic Bag

A507-SL KIT		Inch	mm
E-1st	Plated Steel	.009	0.23
B-2nd	Plated Steel	.011	0.28
G-3rd	Plated Steel	.016	0.41
D-4th	Nickel Alloy Wound	.024	0.61
A-5th	Nickel Alloy Wound	.032	0.81
E-6th	Nickel Alloy Wound	.042	1.07

AE530-SL

ELECTRIC GUITAR STRING

- Plated Steel
- Hexagonal Core
- Nickel Alloy Wound



AE530-SL		
Note	Inch	mm
E-1st	.009	0.23
B-2nd	.011	0.28
G-3rd	.016	0.41
D-4th	.024	0.61
A-5th	.032	0.81
E-6th	.042	1.07



MUSICAL EQUIPMENT

GUITAR STRINGS / ACCESSORIES

- A606(4)-M-1
- A606(4)-M-2
- A606(4)-M-3
- A606(4)-M-4
- A606(5)-M
- A606(6)-M



ELECTRIC BASS STRING

- Acoustic Guitar, Stainless Steel, Silver Plated, Cooper Wound, Extra-Light Strings

A606-M KIT

	Inch	mm
Nickel Alloy Wound	.032	0.81
Nickel Alloy Wound	.045	1.14
Nickel Alloy Wound	.065	1.65
Nickel Alloy Wound	.085	2.16
Nickel Alloy Wound	.105	2.67
Nickel Alloy Wound	.130	3.29

A607(4)-M

ELECTRIC BASS STRINGS

- Electric Bass Strings
- Steel Core
- Nickel Alloy Wound
- Plastic Bag



A607(4)-M KIT

	Inch	mm
Nickel Alloy Wound	.045	1.14
Nickel Alloy Wound	.065	1.65
Nickel Alloy Wound	.085	2.16
Nickel Alloy Wound	.105	2.67

A703

VIOLIN STRINGS

- Violin String
- Steel Core
- Nickel Silver Wound
- Plastic Bag

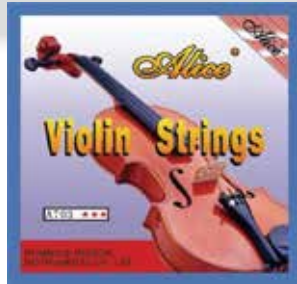

A703 KIT High-Grade

Steel Core, Nickel Alloy Wound
Steel Core, Nickel Alloy Wound
Steel Core, Nickel Alloy Wound

A703A KIT Middle-Grade

Stainless Steel
Steel Core, Nickel Alloy Wound
Steel Core, Nickel Alloy Wound
Steel Core, Nickel Alloy Wound

A705 COMPLETE KIT

- A705-1
- A705-2
- A705-3
- A705-4



VIOLIN STRINGS

- Violin String
- Coated Steel Core
- Nickel Chromium Wound
- Plastic Bag

A705 KIT

E-1st	Stainless Steel
A-2nd	Steel Core, Nickel Chromium Wound
D-3rd	Steel Core, Nickel Chromium Wound
G-4th	Steel Core, Nickel Chromium Wound
G-4th	Steel Core, Nickel Chromium Wound



GUITAR ACCESSORIES / TAMBOURINES

A025A

PICKGUARD

- Guitar Pickguard
- Black



A025B

PICKGUARD

- Guitar Pickguard
- Colorful



AP100N

GUITAR STRING

- Thump Picks
- Assorted Colors



AP-12C

GUITAR PICKS

- Celluloid Picks
- Constellation



AP-12G

GUITAR PICKS

- Projecting Nylon Guitar Picks
- Clamshell



AP-180A

GUITAR STRING

- Thump Picks
- Assorted Colors



Satellite Diplexer

AP-20N

GUITAR PICKS

- Celluloid Picks
- Assorted Colors
- 20 Pcs





MUSICAL EQUIPMENT

TAMBOURINES

ATM-818 BLU

ATM-818 BLK

ATM-818 RED

ATM-818 WHT

DUAL TAMBOURINE

- Hand-Held Tambourine with Metal Jingles
- Most Comfortable and Unique Design
- Natural Wrist Shake
- High-Quality Metal Jingles
- Sonorous and Amusing Sound
- Tambourine Popular Among the Music Lovers



ATM-830

STAR TAMBOURINE

- Hand-Held Tambourine with Metal Jingles
- Most Comfortable and Unique Design
- Natural Wrist Shake
- High-Quality Metal Jingles
- Sonorous and Amusing Sound
- Tambourine Popular Among the Music Lovers



ATM-810 BLU

ATM-810 RED

ATM-810 WHT

TAMBOURINE

- Hand-Held Tambourine with Metal Jingles
- Most Comfortable and Unique Design
- Natural Wrist Shake
- High-Quality Metal Jingles
- Sonorous and Amusing Sound
- Tambourine Popular Among the Music Lovers



ATM-820 BLU

ATM-820 RED

ATM-820 WHT

TAMBOURINE

- Hand-Held Tambourine with Metal Jingles
- Most Comfortable and Unique Design
- Natural Wrist Shake
- High-Quality Metal Jingles
- Sonorous and Amusing Sound
- Tambourine Popular Among the Music Lovers



ATM-DOV-8

TAMBOURINE

- 8" Tambourine



ATM-DOV-10

TAMBOURINE

- 10" Tambourine





MUSICAL EQUIPMENT

TAMBOURINES

ATM-HND8

TAMBOURINE

- 8" Tambourine



ATM-HND10

TAMBOURINE

- 10" Tambourine



ATM-SHI-6

TAMBOURINE

- 6" Tambourine



ATM-SHI-8

TAMBOURINE

- 8" Tambourine

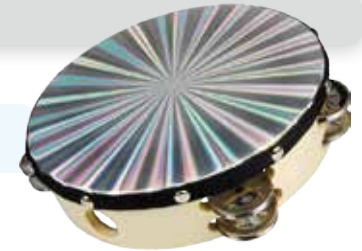

ATM-SHI-10

TAMBOURINE

- 10" Tambourine

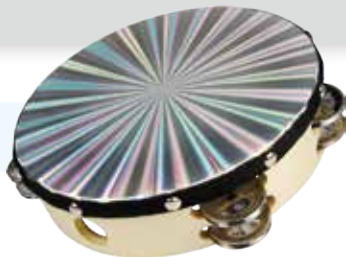

ATM-W6

TAMBOURINE

- 6" Tambourine



ATM-W8

TAMBOURINE

- 8" Tambourine



ATM-W10

TAMBOURINE

- 10" Tambourine





MUSICAL EQUIPMENT

COWBELLS

CB6-DS7KT

DUAL 6" HAND HELD COW BELL

Cow Bell:

- Material: Iron
- Size: 5.1" x 2.8" x 5.9" (129 x 71 x 151mm)
- Weight: 1.15Lb (0.52Kg)
- Includes two

Drumsticks:

- 7A Wood Tip
- Oak Black Drumsticks
- Includes two



ACB-05

5" MOUNTABLE COWBELL FOR DRUM SET

- Designed with the Drum Kit Player in Mind
- High Grade 14-Gauge Steel
- Rich, Cutting Sound is Low Pitched and Moderately Dry



ACB-06

6" MOUNTABLE COWBELL FOR DRUM SET

- Designed with the Drum Kit Player in Mind
- High Grade 14-Gauge Steel
- Rich, Cutting Sound is Low Pitched and Moderately Dry



ACB-07

7" MOUNTABLE COWBELL FOR DRUM SET

- Designed with the Drum Kit Player in Mind
- High Grade 14-Gauge Steel
- Rich, Cutting Sound is Low Pitched and Moderately Dry



ACBH-6

6" HAND HELD COW BELL

- Material: Iron
- Size: 5.1" x 2.8" x 5.9" (129 x 71 x 151mm)
- Weight: 1.15Lb (0.52Kg)
- Hand Held
- Color: Black



ACBP-5BL

5" BLUE PERCUSSION

- Plastic Cowbell



ACBP-6RD

5" RED PERCUSSION

- Plastic Cowbell





MUSICAL EQUIPMENT

DRUMSTICKS

DS-M5A

DRUMSTICKS

- 5A Wood Tip
- Maple Drumsticks



DS-M5A-NL

DRUMSTICKS

- 5A Nylon Tip
- Maple Drumsticks



DS-M7A

DRUMSTICKS

- 7A Wood Tip
- Maple Drumsticks



DS-M7A-NL

DRUMSTICKS

- 7A Nylon Tip
- Maple Drumsticks



DS-M5B

DRUMSTICKS

- 5B Wood Tip
- Maple Drumsticks



DS-OK5A

DRUMSTICKS

- 5A Wood Tip
- Oak Drumsticks



DS-M7B

DRUMSTICKS

- 7B Wood Tip
- Maple Drumsticks



DS-OK7A

DRUMSTICKS

- 7A Wood Tip
- Oak Drumsticks



DS-OK5A-BLK

DRUMSTICKS

- 5A Wood Tip
- Oak Black Drumsticks



DS-OK5A-NL

DRUMSTICKS

- 5A Nylon Tip
- Oak Drumsticks





MUSICAL EQUIPMENT

DRUMSTICKS

DS-DK7A-BLK

DRUMSTICKS

- 7A Wood Tip
- Oak Black Drumsticks



DS-DK7A-NL

DRUMSTICKS

- 7A Nylon Tip
- Oak Drumsticks



DSME-5A-NL

5A NYLON TIP MAPLE
DRUMSTICKS

- Nylon Tip Drumstick
- Normal Size for Adult Use
- Made of Maple



DSME-7A-NL

7A NYLON TIP MAPLE
DRUMSTICKS

- Nylon Tip Drumstick
- Normal Size for Adult Use
- Made of Maple



DS-AH-7A-BLK

AMERICAN HICKORY
DRUMSTICKS

- 7A Wood Tip
- Hickory Black Drumsticks



DS-AH-7A-NWO

AMERICAN HICKORY
DRUMSTICKS

- 7A Nylon Tip
- Hickory Drumsticks



DS-AH-7A-RED

AMERICAN HICKORY
DRUMSTICKS

- 7A Wood Tip
- Hickory Red Drumsticks



DS-AH-7A-YLW

AMERICAN HICKORY
DRUMSTICKS

- 7A Nylon Tip
- Hickory Yellow Drumsticks

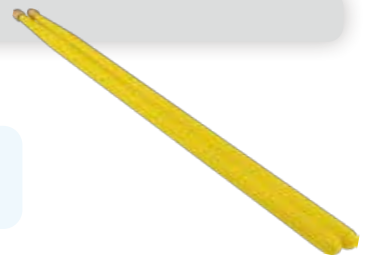

DS-M2B

2B WOOD TIP MAPLE DRUMSTICKS

- Wood Tip Drumstick
- Normal Size for Adult Use
- Made of Maple





MUSICAL EQUIPMENT

TOLEDO GUITARS

ACG-3910CEQ-SB

39" ELECTRO ACOUSTIC CUTAWAY GUITAR

- 5 Band EQ with Microphone
- LCD Display Screen, Chromatic Tuner Display
- Power: 1 x 9v Battery
- With 1/4" and XLR Socket Output
- Color: Sun Burst

Guitar Bag INCLUDED



ACG-3910BLK

39" ACOUSTIC GUITAR

- Color: Black

Toledo

Guitar Bag INCLUDED



ACG-3910CEQ-WH

39" ELECTRO ACOUSTIC CUTAWAY GUITAR

- 5 Band EQ with Microphone
- LCD Display Screen, Chromatic Tuner Display
- Power: 1 x 9v Battery
- With 1/4" and XLR Socket Output
- Color: White

Guitar Bag INCLUDED



ACG-3910CEQ-YH

39" ELECTRO ACOUSTIC CUTAWAY GUITAR

- 5 Band EQ with Microphone
- LCD Display Screen, Chromatic Tuner Display
- Power: 1 x 9v Battery
- With 1/4" and XLR Socket Output
- Color: Yellow

Guitar Bag INCLUDED



ACG-3910BL

39" ACOUSTIC GUITAR

- Color: Blue

**Guitar Bag
INCLUDED**



ACG-3910SB

39" ACOUSTIC GUITAR

- Color: Sun Burst

**Guitar Bag
INCLUDED**



ACG-3910WH

39" ACOUSTIC GUITAR

- Color: White

**Guitar Bag
INCLUDED**



ACG-3910YH

39" ACOUSTIC GUITAR

- Color: Yellow

**Guitar Bag
INCLUDED**





MUSICAL EQUIPMENT

EQUALIZERS/PASSIVE DIRECT BOX

EQ-A7545R

ACOUSTIC GUITAR EQUALIZER

- 4 Band Guitar Equalizer



9V Battery INCLUDED

PS-500

**MULTI-FUNCTION
5-BAND EQUALIZER**

- Volume Control
- 5-Band Equalizer
- Low Battery Indicator



PRO-1

ACOUSTIC GUITAR EQUALIZER

- LED display
- Material: ABS & metal
- Anti-feedback Switch
- Volume control
- 3-Band Equalizers
- Low battery indicator



MTNR-7CLP

DIGITAL CLIP TUNER

- Signal Receipt Method: MIC & CLIP
- A4 Frequency Range: 435~445Hz
- Tuning Mode: For Guitar, Bass & Violin
- Tuning Range: 0A~7C
- Tolerance: ≤ 1 Cent
- LDC Display: Color Back-Light Display
- Red to Green Status Indicator
- Battery: CR2032
- Size: 53x80x43(mm)
- Weight: 53G



Battery INCLUDED

PICKUP-50

STANDARD PICKUP

- Easy to Install to Most Acoustical Instruments



PICKUP-60V

PICKUP

- Violin Pickup



PICKUP-70G

GUITAR PICKUP

- Exclusively for Acoustic Guitar
- Easy to Attach to Guitar



PICKUP-105G

ACOUSTIC GUITAR PICKUP

- Can Fit 3-11/16 to 4-1/8 (94-105mm) Sound Hole
- Excellent Bass Midrange Response and Soft Acoustic Tone



GM-130

GUITAR PICKUP

- Acoustic Guitar Pickup





MUSICAL EQUIPMENT

INSTRUMENTS / ACCESSORIES

GUIRO-310B

PERCUSSION INSTRUMENTS

- 15"
- Diameter 3"



GUIRO-412

PERCUSSION INSTRUMENTS

- 12"
- Diameter 4"



GUIRO-512

PERCUSSION INSTRUMENTS

- 12"
- Diameter 5"



GUIRO-612

PERCUSSION INSTRUMENTS

- 12"
- Diameter 6"



ARC-820

IVORY RECORDER

- Includes a Bag
- Lyons Recorder Cleaning Rod
- Approximately 12.50" Long

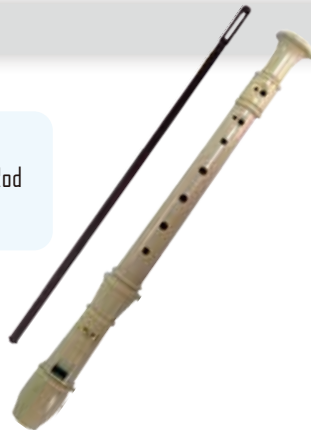

AHM-160

HARMONICA

- Metal & Wood
- Silver
- In C Key

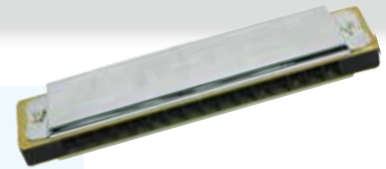

AMRC-06

MARACAS

- Plastic Concert Maracas with Wood Handles



ABG-40

BONGO

- 7" & 8" Wooden Shell





MUSICAL EQUIPMENT

GUITAR STRAP ACCESSORIES

ZGS-1

STRAP

- Guitar Strap



ZGS-7

STRAP

- Guitar Strap



ZGS-8

STRAP

- Guitar Strap



ZGS-9

STRAP

- Guitar Strap



ZGS-10

STRAP

- Guitar Strap



ZGS-P140BK

STRAP

- Guitar Strap



ZGS-P140MI

STRAP

- Guitar Strap



A040-LB

STRAP

- Guitar Strap



A026A

A026B/IVY

GUITAR NUT

- Acoustic Guitar Nut



A026C/IVY

GUITAR SADDLE

- Acoustic Guitar Saddle



GUIRO-BRUSH-12

GUIRO BRUSH

- Length: 305mm/12"



CL-1001

10" CLAVES

- Wood Color



GBN-01CL-39

GUITAR BAG

- 39" Guitar Strap



GBN-06CL-39

39" CLASSICAL GUITAR BAG

- Long Edge Zipper
- Two Shoulder Straps

